



- Proven optical measurement technique
- No moving parts/low maintenance
- Simple installation/operation
- Rugged construction
- Designed specifically for tunnels
- PC utility software included
- Readings in Extinction (k), MOR or Opacity
- Resolution of 0.1%
- Isolated 4-20mA analogue outputs
- Alarm relay contacts
- Choice of serial comms protocols

The VIPA tunnel monitor uses the universally accepted light transmission opacity technique to determine a reliable visibility measurement in tunnels. It is a single pass transmitter/receiver system with a recommended path length of 10m. It can make measurements in either opacity (%), extinction coefficient (k), or Meteorological Optical Range (m) to a resolution of 0.1% opacity. Having been designed specifically for harsh tunnel environments, the VIPA monitor is a rugged construction using powder coated stainless steel and flame retardant polycarbonate to achieve an IP65 / NEMA 4X protection rating. This instrument that can withstand the corrosive atmosphere and regular tunnel washing that the tunnel environment endures.

The VIPA monitor is supplied with a control unit (known as an Operator Interface, or OI) which provides a human interface in the form of a keypad and display, and also standard SCADA/PLC interface options such as 4-20mA outputs, alarm relay contacts, and a choice of serial communications protocols.

The OI is connected to the receiver head via a single umbilical cable which can be up-to 1km long. This allows the transmitter/receiver heads to be mounted on the tunnel wall, whilst the OI is located in a local panel or remote control room elsewhere. The VIPA is also supplied with a PC based utility software which can be used to set-up and control the instrument remotely.

The VIPA visibility monitor has no moving parts and is consequently very reliable. The regular service requirement consists of lens cleaning (typically every six months). The lenses are protected by a 40cm quick release sight tube which creates a still air corridor in front of the optics – further extending the service interval. The instrument performs a number of self checking and diagnostic routines, which in the unlikely event of a fault condition can identify the fault and report it via the service alarm relay and/or serial comms.



Specification:

Measurement Performance

No.	Parameter	Units	Min	Max	Comment
1	Path length	m	6	20	10m recommended
2	Display range				User selectable
	Transmission	t	0	1.000	
	Extinction Coefficient (k)	m ⁻¹	0	0.1000	
	Meteorological Optical Range (MOR)	m	0	15000	
3	Resolution				Display resolution
	Transmission	t		0.001	
	Extinction Coefficient (k)	m ⁻¹		0.0001	
	Meteorological Optical Range (MOR)	m		1	
4	Accuracy	Opacity	%	0	999
		Extinction Coefficient (k)	m ⁻¹	-0.002	+0.002
5	Damping	s	0	999	Default setting is 10s
6	Temperature Stability	Opacity	%	-2	+2
		Extinction Coefficient (k)	m ⁻¹	-0.002	+0.002

Power

8	Voltage	VDC		+24	
9	Voltage Tolerance	%	-10	+10	
10	Nominal Current Consumption	mA		200	
11	Power Up Current Consumption	mA		200	

Interface Options

12	Serial outputs				RS485 (on terminals) RS232 (on 9 pin D header) ModBus, ProfiBus, DeviceNet, Ethernet etc. (on plug in modules in the OI)
13	Analogue Outputs (1 output)	V mA	0.0 4.0	10.0 20.0	Isolated and scalable Isolated and scalable
14	Digital Relay Contacts	A	0	3	@30VDC (Separate service and threshold alarms with separate contacts)

Physical

15	Ingress Protection			IP65	
16	Operating Temperature	°C	-20	+50	
17	Operating Humidity	%	5	100	
18	Regulatory Compliance				89/336/EEC (Electromagnetic Radiation)
19					73/23/EEC (Low Voltage)
20	Materials				Powder coated stainless steel/polycarbonate
21	OI dimensions	cm		24x21x21	L x W x H
22	TX/RX dimensions (each)	cm		51x16x17	L x W x H
23	OI weight	Kg		1.0	
24	TX/RX weight (each)	Kg		3.5	
25	Warranty	Months	24		Return to base warranty. Extensions available.
26	Mean Time Between Failure	Years		10	





Configuration Options:

Remote OI <=200m Configuration

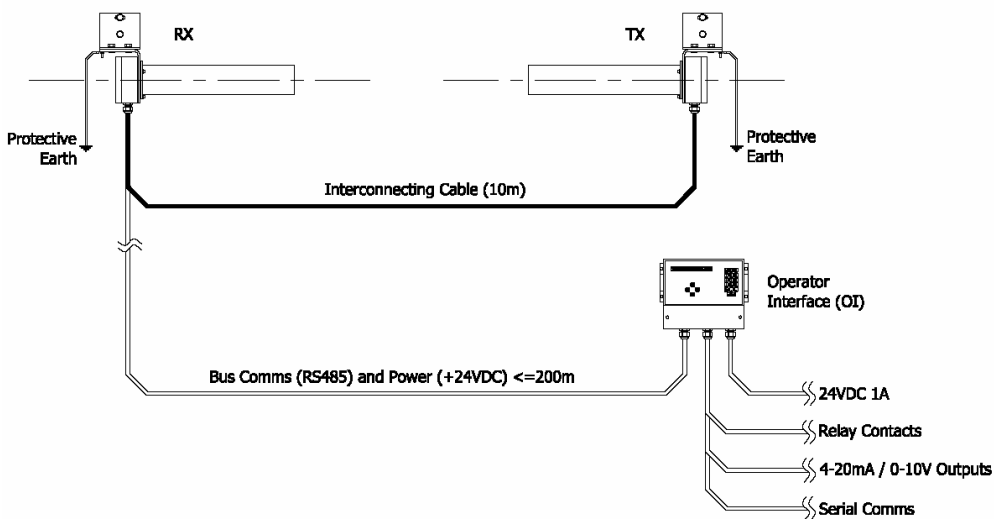

Remote OI <=1000m Configuration

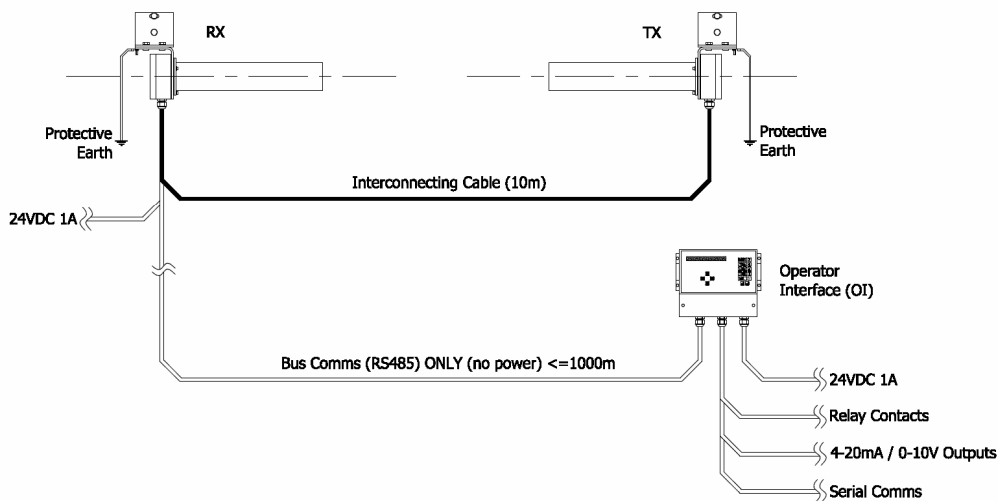



TUNNEL SENSORS

VIPA Visibility Monitor for Tunnels

Dimensions:

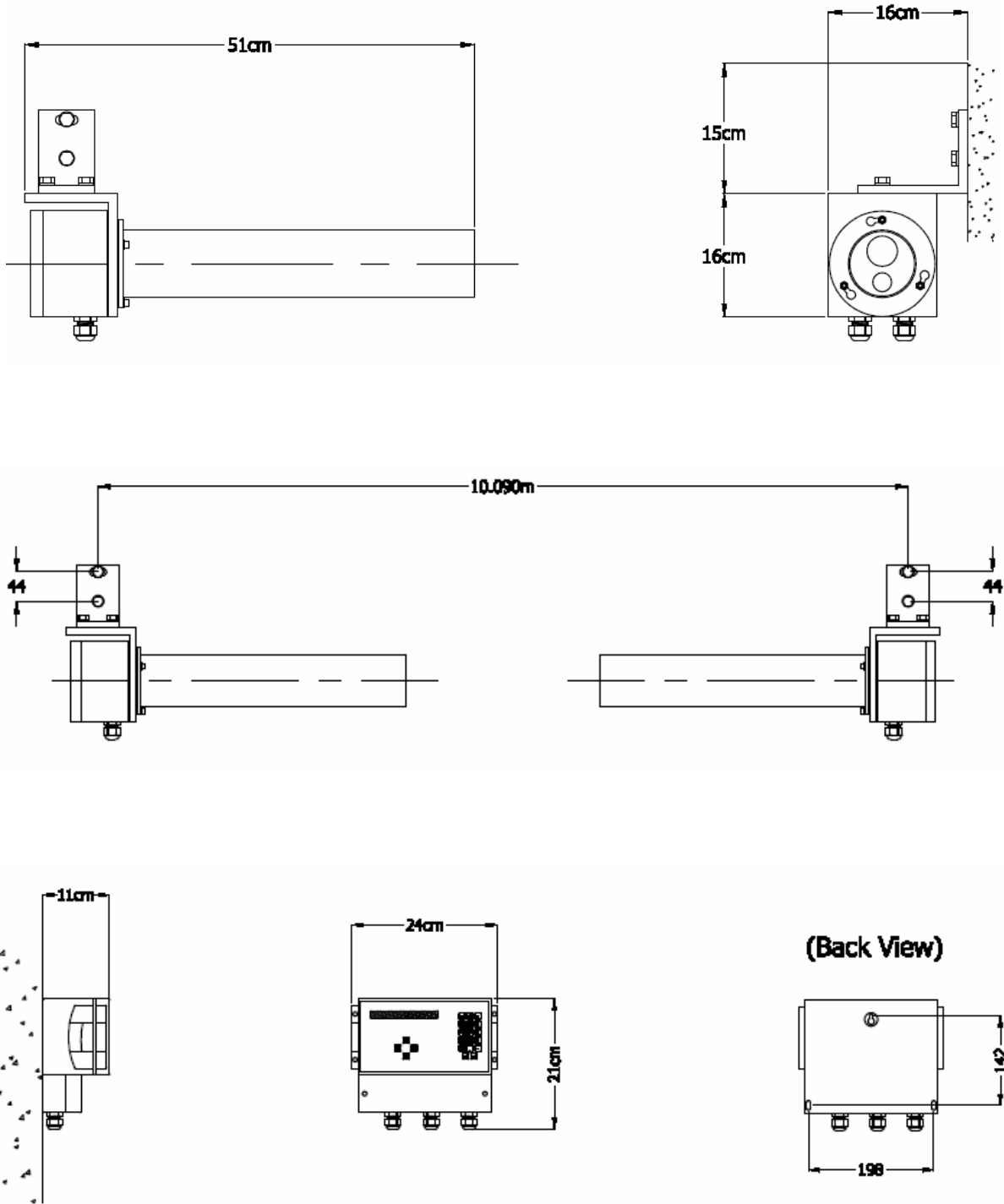

Tunnel Sensors Ltd, Furlong House, Crowfield, Brackley, Northamptonshire NN13 5TW United Kingdom
Telephone: +44 (0)1280 850563, Facsimile: +44 (0)1280 850568
Email: contact@tunnelsensors.com, Web site: www.tunnelsensors.com



© Tunnel Sensors Ltd 2009
02/04/2009 V1.7

All technical details and specifications are subject to change without notice





TUNNEL SENSORS

VIPA Visibility Monitor for Tunnels

Accessories & Ordering:

Ordering Details

Description	Order Code	Notes
VIPA visibility monitor with utility software 	TSL-VIPA	24VDC power supply required
Visibility attenuation grid with snout for sight tube mounting 	TSL-NC-003	
25W 24VDC power supply with universal single phase AC input, boxed in IP67 protected polycarbonate enclosure with dual gland entries 	PSU-007	
LSZH screened multi-core cable for VIPA/OI connection 	CBL-046	Order by the meter i.e. for 10m order 100ft
Belden equivalent screened multi-core cable for VIPA/OI connection 	CBL-078	Order by the meter i.e. for 10m order 100ft



Tunnel Sensors Ltd, Furlong House, Crowfield, Brackley, Northamptonshire NN13 5TW United Kingdom
 Telephone: +44 (0)1280 850563, Facsimile: +44 (0)1280 850568
 Email: contact@tunnelsensors.com, Web site: www.tunnelsensors.com



© Tunnel Sensors Ltd 2009
 02/04/2009 V1.7

All technical details and specifications are subject to change without notice